

# **Department of Markets and Consumer Protection**

## **Code of Practice for Deconstruction and Construction Sites**

**Sixth Edition – FEBRUARY 2011**



Department of Markets and Consumer Protection  
City of London  
PO Box 270  
Guildhall  
London  
EC2P 2EJ

## **Foreword**

This is the sixth version of the Code of Practice developed by the City of London's Pollution Control Team to encourage the use of the best environmental options in planning and managing construction and deconstruction (demolition) in the City of London. The area is densely populated by residents, many types of business, and other sensitive premises, all of which can be affected by your work and associated activities.

This Code seeks to set out simply and clearly what constitutes acceptable site practice within the City. It is intended to help developers, architects, engineers and construction professionals to plan, cost and manage the environmental issues which frequently arise in the industry.

In the City we encourage a flexible approach to addressing environmental problems. I must emphasise that this needs early and, in some cases, frequent liaison with the officers in the Pollution Control Team who should be consulted at all stages of project planning, programming and operation, so that the best options for your site can be developed.

This sixth edition of the code generally revises and updates the original version. It contains further guidance on prevention of air pollution from activities on site, and a number of forms and check lists have also been improved.

Additionally, we encourage you all to apply, via our Considerate Contractors Scheme (CCS), for the Environmental Award. This will recognise those sites/companies who innovate to protect the Environment in the City each year, and this year will look in particular at improvements in the field of air quality.

The Code takes into account current best practice and new technology already adopted by many sites in the City.

I hope you will find this guidance useful in planning and managing your site activities.

**Jon Aaverns**  
**Port Health and Public Protection Director**

<b>Contents</b>	<b>Page</b>
1.0 Introduction	1
2.0 Use and Application of the Code of Practice	1
3.0 Considerate Contractors Scheme	2
4.0 Documentation	2
5.0 Liaison	2
6.0 Hours of Work	3
7.0 Air Quality and Dust	5
8.0 Smoke and Fume Nuisance	7
9.0 Noise and Vibration	7
10.0 Complaints to site	10
11.0 Section 60 and 61 Notices	11
12.0 Emergency Work	11
13.0 Pollution Emergencies	11
14.0 Party Wall Work	12
15.0 Scaffolding and Gantries	12
16.0 Cranes, Lifting of Equipment and Road Closures	12
17.0 Vehicle Movements and Deliveries	13
18.0 Light Pollution	14
19.0 Asbestos & Hazardous Materials	14
20.0 Contaminated Sites	14
21.0 Waste Management	15
22.0 Materials Handling and Storage	16
23.0 Discharge of Waste Water from Site	16
24.0 Site Drainage, Temporary and Permanent Connections to Sewers	16
25.0 Pest Control	17
26.0 Conservation	18
27.0 Archaeology and Built Heritage	18
28.0 Climate Change and Sustainability	19

## **Appendices and Forms**

A	Guidance and legislation
B	Contact details for City departments & external agencies.
C	The City's considerate contractor scheme
D	Scaffolding Requirement
E	Standard requirements for sewer connections
F	Traffic management summary of requirements for vehicle movements, site deliveries, crane operations & abnormal loads.
G	Site information form.
H	Site hours variation request form
I	Mobile crane authorisation request form
J	Map showing streets with residents
K	Code of Practice checklist
L	Environment Award

*Note: Copies of this Code of Practice can also be accessed via the City's website at:*  
[http://www.cityoflondon.gov.uk/Corporation/LGNL\\_Services/Environment\\_and\\_planning/Pollution/noise.htm](http://www.cityoflondon.gov.uk/Corporation/LGNL_Services/Environment_and_planning/Pollution/noise.htm)

## 1.0 Introduction

- 1.1 At any one time there are many active deconstruction, construction and refurbishment sites within the City of London. The work is essential in order to enable the City to maintain its status as a world class centre of business and finance. Some of the activities involved and listed in this document can often be a nuisance to neighbours and users of the surrounding area. To ensure that activities are undertaken with minimal disturbance, the City of London has prepared this Code of Practice detailing the standards to which they expect sites to be maintained and operated.
- 1.2 The environmental impacts of construction work should be considered as early as possible in the project. Where potential adverse impacts are identified, measures to offset or reduce them should be incorporated into the project proposals at the earliest stage and taken into account in the final cost. These matters should form part of the Environmental Management Plan (EMP) to be submitted to the Pollution Team in the Department of Markets and Consumer Protection. We wish to encourage best practice and new innovation in Environmental Matters and welcome all companies/sites to take part in the CCS Environment Award.

**Note:** The term Contractor used within this Code of Practice includes Principal Contractors, Construction Managers, Trade Contractors and other similar roles. Ultimate responsibility rests with the Principal Contractor although the developer (or promoter of the project) will clearly have an interest in ensuring that works are undertaken with minimum disruption.

## 2.0 Use and Application of the Code of Practice

- 2.1 This Code is intended as a guide to good practice but should not replace consultation between developers, contractors and regulators. Throughout all stages of a project, discussion with the City of London is actively encouraged. The Code will be forwarded to developers during the planning application process as an informative document, allowing the developer to discuss terms tailored to their specific development with the City of London. Developers should ensure that Contractors are fully aware of this Code and its implications.
- 2.2 Adherence to this Code will demonstrate a positive attitude and commitment towards minimising environmental impacts and will be used as one of the main methods of assessment within the City's Considerate Contractor Scheme.
- 2.3 The Code follows a methodical approach to construction works and sets standards to be followed. Not all parts of this Code will apply to every construction project. However, the City will expect all Contractors to comply with the spirit of the Code, with appropriate provisions being applied to the site at all times. This should allow local residents and businesses to continue operating with minimal disturbance.
- 2.4 Although this Code gives an outline of legal requirements, it is not an authoritative statement of the law. Where necessary in accordance with its policy statement on enforcement, the City of London will not hesitate to enforce the statutory powers they have. A list of relevant guidance and legislation are included as Appendix A. A

checklist to help ensure that all relevant areas of concern are considered is set out in Appendix K.

### **3.0 Considerate Contractor Scheme**

- 3.1 The Considerate Contractor Scheme (CCS), pioneered by the City of London in 1987, aims to encourage building and civil engineering contractors working adjacent to the City's streets to carry out their operations in a safe and considerate manner, with due regard to passing pedestrians and road users. Details are set out in Appendix C of this Code. As part of the scheme, all contractors will be evaluated by the Pollution Team for their level of co-operation and compliance with this Code of Practice.

### **4.0 Documentation**

- 4.1 The Contractor should keep all appropriate documentation relevant to the requirements of this Code in designated files held on site. They must be available at all times for inspection and review by the City of London or other authorities and should include as a minimum a site information sheet, noise, vibration and dust monitoring results, waste management documentation, a complaints/incidents log with actions taken, liaison minutes, letters, photos and newsletters.
- 4.2 The City requires the development of project-specific Environmental Management Plans (EMP) and Site Waste Management Plans in accordance with Defra guidelines. These are operational manuals for carrying out appropriate environmental controls and monitoring during the works and should, as a minimum, cover the issues within this Code (see Appendix K for Checklist).

### **5.0 Liaison**

- 5.1 Prior to work commencing, the Contractor must meet with the City of London Environmental Services, Highways Division, and the Pollution Team, in order to discuss their methods of working and measures planned to minimise disruption. Throughout the construction works, further meetings with the City may be held. The names and contact details of appropriate site personnel should be forwarded to the Pollution Team using the Site Information Sheet (Appendix G) at the earliest opportunity. A list of useful contact names and telephone numbers is included in Appendix B.
- 5.2 The Contractor should identify any residential properties, lunchtime catering premises, public houses or other sensitive receptors in close proximity to the site. In the first instance, reference should be made to the Residential Streets map (Appendix J), which identifies residential areas within the City. New residential developments are continually appearing, so the Pollution Team should be contacted in order to obtain the most up to date information.
- 5.3 The Contractor should appoint a responsible person to liaise with the City, local residents, businesses and other authorities in order to keep them informed of matters

likely to affect them. Good relations can be developed by keeping neighbours informed of progress and by responding to complaints quickly and fairly.

- 5.4 Prior to site work commencing, neighbours must be informed of:
- The start date;
  - the duration and nature of the project;
  - the principal stages of the project;
  - details of contact names and numbers of appropriate site personnel.
- 5.5 There shall be at least fortnightly communication with site neighbours, for example by newsletter, in order to keep them informed about current progress and forthcoming works. The newsletter should also contain the information suggested in section 5.4 above, together with details of the Pollution Team contact. Feedback should be requested from affected neighbours throughout the project and at the end, in order to allow modification of activities to reduce impact.
- 5.6 Where construction activities are being undertaken on two or more sites in close proximity, regular meetings should be arranged and attended by representatives from each site and the City of London. Items for discussion may include:
- Activities to be undertaken;
  - requirements for road closures;
  - out of hours work;
  - neighbour liaison;
  - monitoring results; and,
  - requirements for mitigation.
- 5.7 A display board should be erected outside the site, which as a minimum shall identify key personnel, contact addresses and telephone numbers. Additional information could include details of the scheme and its progress.
- 5.8 The City of London must be told in advance when any unusual activities including out-of-hours working are planned. The Site Hours Variation Request Sheet (Appendix H) must be completed and faxed to the Pollution Team at least 5 days before the activity is to take place. Approval or the reasons for refusal will be countersigned and faxed back. Unless approval is given and the sheet is available for inspection, an officer attending the site shall stop all works.
- 5.9 The Pollution Team of the Department of Markets and Consumer Protection must be supplied with a current 24-hour call out number that will be answered in the case of a complaint or an emergency.
- 5.10 It is also recommended that contractors contact the City of London Police service to ensure a security assessment is carried out.

## **6.0 Hours of Work**

- 6.1 If no-one is disturbed by works then there is no absolute bar to 24-hour working. However, such circumstances are rare in the City. Where residents and commercial

activities are affected or are likely to be affected, the permitted times of operation will be restricted.

6.2 Permitted hours for site work will normally be the following:

- 08:00 - 18:00 hours (Monday to Friday);
- 08:00 - 13:00 hours (Saturday) (certain noise sensitive residential areas identified by the City of London will be 09:00 - 14:00 hours on Saturdays);
- No working is permitted on Sundays or Bank Holidays.

**Note:** Prior to commencing work, contractors must contact the Pollution Team in order to agree hours of work.

6.3 The work hours may be varied according to local circumstances, for example where a site is in close proximity to restaurants, places of worship or residential properties.

6.4 Any works outside the permitted hours can only be undertaken with the approval of the City using the Site Hours Variation Request Sheet (Appendix H), and will only be granted in exceptional circumstances. **Approval will be conditional on the Contractor informing local residents in advance of the proposed work.**

6.5 In most cases, the City operates quiet working periods during which noisy site operations are not permitted. Contractors will adhere to these quiet hours at all times unless agreed otherwise with a member of the Environmental Services Pollution Team. The quiet hours are:

- 10:00 - 12:00 (Monday to Friday);
- 14:00 - 16:00 (Monday to Friday).

These periods may be subject to variation in particular circumstances, for example during lunchtimes adjacent to eating places or businesses where the majority of trade is carried out at lunchtimes.

6.6 During these quiet periods the following activities cannot be carried out:

- Cutting using power tools;
- Breaking or dismantling using power tools/machines/plant;
- The use of impact fasteners;
- The loading of heavy materials;
- Other noisy activities, depending on the specific location of site and neighbours, deemed unacceptable by Environmental Health Officers.

Quiet hours are put in place to give nearby commercial occupiers at least 4 hours of peace and quiet during the working day. Complaints about excessive noise disturbance found to be justified may result in a Section 60 notice, under the Control of Pollution Act 1974, being served by the City of London. This will generally require the Contractor to adhere to these quiet working hours.

6.7 Where, in the opinion of Environmental Health Officers, structurally transmitted noise adversely affects neighbours, a likely restriction between 09:00 - 17:00 hours will be imposed. For complex sites with a neighbour mix including residential, retail, and commercial properties, advance negotiation with all parties and the Pollution

Team is expected of the Developer/Contractor, as restrictions may have significant implications for cost and timing of the project. For more information on structure borne noise see Section 9.0 (Noise and Vibration).

## **7.0 Air Quality and Dust**

7.1 Under Part IV of The Environmental Act 1995 and the Governments UK Air Quality Strategy, Local Authorities are required to work towards achieving national air quality objectives. The City of London has some of the worst air quality in the Country and has been declared an Air Quality Management Area with particular focus on PM<sub>10</sub> and oxides of Nitrogen. With the UK likely to receive large fines for the EU in the near future for exceeding air quality objectives and recent studies demonstrating that air quality and dust have a very large impact on public health in London, this issue is currently of the highest priority. Construction and de-construction sites in the City are therefore expected to meet the highest possible standards for control of air pollution and dust.

7.2 A dust and air quality management plan must be produced (potentially as part of the EMP) and submitted to the Pollution Team. This plan must contain a detailed methodology laying out details of, and controls over, all relevant activities. The plan must consider the entire lifetime of the project and sequence of works, and consider many details such as the water supply for the site, plans to deal with debris, specific areas to be encapsulated, scaffolding, and waste management.

7.3 In order to reduce pollution in the City, the construction and demolition industry is expected to employ, as a minimum, all methods listed below. The requirements are in line with the Greater London Authority and London Councils Best Practice Guide for Controlling Dust and Emissions from Construction and Demolition, November 2006.

### **7.4 General Activities**

- Dusty activity should be undertaken away from sensitive receptors, with wind direction taken into consideration.
- The site should be regularly inspected for spillages of cement and other powders.
- Air quality monitoring may be required where practical. This may include dust slides for assessing nuisance dust and real time monitoring to assess PM<sub>2.5</sub> and PM<sub>10</sub>. Real time monitoring may involve setting an alarm to alert the site manager if levels of PM<sub>10</sub> go above a set threshold. The threshold value, and type and location of any monitoring equipment should be agreed with the City of London Pollution Team in advance.
- Dusty material and activities should be dampened down in dry weather. The use of groundwater should be investigated and water should be reused wherever possible.
- All sites should be screened / wrapped.
- Rubber chutes should be used and drop heights minimised.
- Scabbling will not generally be allowed in the City due to the amount of dust generated. It should be done off site.
- Areas used for the storage of diesel fuel or chemicals shall be bunded.
- Off-site fabrication, or cutting to size, shall be employed to avoid cutting materials on site whenever possible.

- Careful consideration should be given to the location and temperature control of tar and asphalt burners.

## 7.5 Machinery / Equipment on Site

- All Non-Road Mobile Machinery (NRMM) should meet Stage IIIA emission criteria, unless it can be demonstrated that Stage IIIA equipment is not available. If Stage IIIA equipment is not available, NRMM should be fitted with particle traps and/ or catalytic exhaust treatment wherever possible. Records should be kept on site which detailing proof of emission limits for all equipment.
- Dust extraction should be used (or built in water damping) with stone cutting disc equipment.
- An inventory of all non road mobile machinery should be kept on site. All machinery should be regularly serviced.
- The use of 'long arm' demolition equipment and methods using explosives will not generally be sanctioned in the City, except where the work is within an enclosure or underground.
- Shears and guillotines or burners should be used in preference to disc cutters on activities such as re-bar and decking.
- The use of concrete crushers will not generally be sanctioned in the City because of the potential to cause dust and nuisance to neighbours. However the City of London will allow the use of crushers to prepare material for piling mats and ramps, as this reduces the number of vehicle movements associated with the site. Any crushing plant would have to be authorised under the Environmental Protection Act 1990. Appropriate measures, such as enclosing the plant and built in water sprays would have to be used at all times.
- Cutting, grinding and sawing should ideally be undertaken off site. If the work must take place on site, the following techniques should be used:
  - All equipment should be fitted with a water suppressant system (where available).
  - Dust extraction techniques should always be used where available. It will be the contractor's responsibility to demonstrate that they are not available, and that every effort has been made to acquire them.
  - Areas used to undertake cutting and grinding should be screened

## 7.6 Vehicles

- No vehicles should be left idling either on site or waiting for access to the site.
- Wheel washers should be used on vehicles leaving the site.
- All skips and lorries leaving the site should be covered.
- When preparing the environmental method statement, the contractor should have regard to The Building Research Establishment 'Pollution Control Guide' for construction (and demolition) sites. The Guide is produced in five parts covering the following construction site activities:
  - Part 1 - Pre-project planning and effective management
  - Part 2 - Site preparation, demolition, earthworks and landscaping
  - Part 3 - Haulage routes, vehicles and plant
  - Part 4 - Material handling, storage, stockpiles, spillage and disposal
  - Part 5 - Fabrication processes and internal and external finishes

The guides are available from the BRE bookshop at <http://www.brebookshop.com/details.jsp?id=144548>

## **8.0 Smoke and Fume Nuisance**

- 8.1 Emphasis should be placed on the following to minimise the risk of air pollution:
- Using processes which do not generate fumes and/or dust; and
  - Ensuring that fumes and/or dust do not escape from the site to affect members of the public and the surrounding environment.
- 8.2 Burning of materials on site is not permitted under any circumstances.
- 8.3 The Contractor should take all necessary precautions to prevent the occurrence of smoke emissions or fumes from site plant or stored fuel oils. In particular, plant should be well maintained and measures taken to ensure that they are not left running for long periods when not in use. Low sulphur diesel fuel must be used.
- 8.4 The Contractor should conduct a risk assessment including regular air monitoring where there is evidence of volatile or airborne materials or a risk of fumes affecting the local area. The Contractor shall take any necessary measures to prevent nuisance/adverse effects to people's health.

## **9.0 Noise and Vibration**

- 9.1 This Code of Practice is a notice of the City of London's general requirements under Section 60 of the Control of Pollution Act 1974. The Contractor may also be informed of additional requirements during consultations with the City of London.
- 9.2 In addition to working hours and community liaison, all works must be carried out in accordance with BS 5228-1:2009 and BS 5228-2:2009.
- 9.3 All works must employ Best Practicable Means as defined by Section 72 of the Control of Pollution Act 1972 to minimise the effects of noise and vibration. The City must be satisfied that all means of managing and reducing noise and vibration, which can be practicably applied at reasonable cost, have been implemented.
- A written evaluation of methodologies used must be made available to the City of London and include justifications with regards to the minimisation of noise and vibration.
- 9.4 The City considers the off-site preparation of as many materials as possible an essential requirement for Best Practicable Means, in particular for the cutting of decking and steelwork.
- 9.5 Where appropriate, the following measures to minimise noise and vibration levels should be adopted:
- Employing only modern, quiet and well-maintained equipment (all equipment must comply with the EC Directives and UK Regulations set out in BS 5228-1:2009);

- Using low impact techniques, such as demolition munchers and bored or hydraulically-jacked piling rigs;
- careful planning of the sequence of work in order to minimise the transfer of noise/vibration to neighbours;
- using fully silenced modern piling rigs with engines to Euro Standard IV and careful operation of the rig so there is no reversing of the Kelly/auger bars;
- using electrically powered equipment run from the mains supply, or when this is not available, generators compliant with Euro Standard IV;
- use of screws and drills rather than nails for fixing hoardings etc;
- careful handling of materials & waste such as lowering rather than dropping items;
- taking steps to isolate the deconstruction works from sensitive neighbours, in order to minimise the transfer of vibration and structure borne noise;
- erection of acoustic screens where necessary;
- avoidance of unnecessary noise (such as engines idling between operations, shouting, loud radios or excessive revving of engines) by effective site management.

9.6 The distance between noise/vibration sources and sensitive neighbours should be maximised and the transmission path obstructed, with options considered in the order of source-pathway-receptor. Where practical this can be achieved by:

- Sitting of stationary plant and loading/unloading areas;
- erecting impervious hoardings, of at least 5 kg/m<sup>2</sup> surface density, where possible higher than the line of sight to neighbours;
- leaving building façades and boundary walls intact as long as possible during demolition and boarding/bricking up windows;
- the use of existing non-sensitive structures as shields; and,
- the use of temporary structures;
- cutting of transmission pathways for vibration.

In addition to the above, a neighbour liaison scheme must be implemented as an essential element of the Best Practicable Means to minimise the effects of noise and vibration, as outlined in Section 5.

### **Monitoring Regimes**

9.7 The City encourages contractors to undertake regular intelligence-led monitoring of noise and vibration levels by looking at the work programme and identifying aspects likely to cause significant noise/vibration. Receptor points are to be agreed with the City of London prior to initiation of monitoring. Results should be compared against suitable baseline data as a useful means of:

- Controlling noise and vibration, and identifying problems at an early stage (it is particularly valuable to carry out monitoring during the early stages of a project);
- providing an objective basis for evaluating complaints;
- safeguarding Contractors against claims of damage.

9.8 Prior to commencing work, it is essential to undertake monitoring of ambient noise levels around the site at sensitive receptors. This will provide baseline data for

comparison with levels present during the works. A baseline vibration exercise will be unnecessary unless neighbours are clearly affected by any existing source of substantial vibration e.g. a tube line.

- 9.9 Where there are party walls or neighbours are otherwise directly attached to elements of the site, the noise, vibration and structural implications of the proposals will require individual and detailed evaluation.
- 9.10 In some circumstances, the Pollution Team may require continuous monitoring combined with a real-time alarm system, with details to be agreed on an individual basis.

### **Noise Limits**

- 9.11 The suitability of specific noise limits is highly dependent upon the individual situation. The factors to be considered include:
- The characteristics of the noise and its potential effect on the neighbours;
  - Baseline ambient noise levels; and,
  - The nature and duration of the works.

In addition, following complaints specific noise levels may be set to prevent speech interference in offices and loss of trade.

Levels of 75 dB a working day over a 10-hour period are suggested as a general rule. The City of London expects noise control to meet or reduce the average noise from the site to this level. In the city environment this is not always attainable, in which case best practicable means must be applied to reduce noise and vibration as far as possible.

As a guide, typical daytime levels for noisy temporary works at neighbouring premises usually lie in the range of 70 – 80 dB  $L_{Aeq}$ .

- 9.12 Noise levels within neighbouring offices or residences during noisy periods must enable workers to carry out conversations, both face-to-face and on the telephone, and allow normal business to be conducted. It is considered that a noise level of 65 dBA is likely to cause annoyance and interference (dependent on the type of noise). Such noise should be restricted to hours outside the normal working day of 09.00 – 17.00 hours.

In residential areas, timings of works with noise levels exceeding 65dBA should be discussed and agreed with Environmental Health Officers prior to commencing.

- 9.13 Noise measurements should ideally be taken with a Class I Integrating Logging Sound Level Meter calibrated (before and after) with a Class I Acoustic Calibrator.  $L_{Aeq}$ ,  $L_{C_{peak}}$  and  $L_{AF_{max, F}}$  noise levels should be recorded together with a record of all events potentially affecting the noise level at the time of monitoring.

## **Vibration Limits**

- 9.14 When carrying out works which may produce vibration, all potential receptors should be considered, with particular attention to be paid to the following:
- Occupiers and users of buildings;
  - Hospitals or laboratories;
  - IT related issues; and,
  - Cosmetic or structural damage to buildings or heritage sites.
- 9.15 People's response to perceptible vibration is accentuated by their fear of building damage. Suitable guidance upon the levels of vibration, which may cause building damage, can be found in BS 7385-2:1993.
- Guidance relating to the potential effect upon the operation of computers and other relatively sensitive equipment can be found in Section 8.6 of BS 5228-2:2009.
- 9.16 Complaints of vibration are usually concerned with fear of the unknown and the potential affects of relatively low levels of vibration in buildings. This problem is best addressed by:
- Liaison with all parties potentially affected, with explanations given of precisely when they are likely to be affected by specific activities;
  - Monitoring affected parties to reassure occupants as to the relative levels of vibration compared with building effect (BS 7385-2:1993).
- 9.17 Vibration meters should preferably record 3 orthogonal Peak Particle Velocity values (15 minutes of 10 second or shorter samples). Where complaints are received, the Contractor/client should consider the need for monitoring at neighbouring premises.

## **10.0 Complaints to Site**

- 10.1 Where complaints are made to the site, the Contractor is expected to respond sympathetically. If no resolution can be found the complaint should be referred to the City of London. A contractor's response to complaints is an important criterion when evaluating the performance of the site for the Considerate Contractor Scheme.
- 10.2 The Contractor must maintain a designated complaints/incidents logbook or register covering:
- The nature of the complaint;
  - the cause; and, where appropriate,
  - the remedial action taken.
- 10.3 The City may request to see the complaints/incidents logbook at any time.
- 10.4 Complaints received by the City of London will be investigated. This will involve discussions with the Contractor and, if appropriate, monitoring or surveillance.

## **11.0 Section 60 and 61 Notices**

- 11.1 The Control of Pollution Act 1974 Part III restricts and limits noise and vibration from a construction site. If complaints are received the City of London Port Health and Public Protection Division, where it is considered necessary, will serve a Section 60 notice on the Contractor for the control of noise and vibration at the site. This notice can:
- Specify the plant or machinery that is or is not to be used;
  - specify the hours during which work can be carried out; and/or,
  - specify the levels of noise and vibration that can be emitted from the site.
- 11.2 The Contractor can apply in advance for a consent in the form of a Section 61 notice regarding the methods and conditions by which they are intending to undertake the works and control nuisance.
- 11.3 The City does not advise the use of Section 61 consents but it does support a system of prior agreement on similar lines, as this allows a much more flexible approach of greater benefit to the Contractor. Section 60 notices will be served where they are considered necessary. Contraventions of either Section 60 or 61 may well result in legal proceedings, leading to further costs and delays for the Contractor.

## **12.0 Emergency Work**

- 12.1 The City of London appreciates that occasionally incidents arise whereby it is impossible or impractical to comply with all the requirements within this Code. In such an event, the Pollution Team should be contacted within the hours of 08:00 and 17:00. Outside of these hours Guildhall security should be called on 0207 606 3030, leaving a name, mobile number, the nature of the emergency, and the site address. Following this the Environmental Health and Public Protection Out of Hours Officer will respond by calling the contractor in order to ensure the presence of an emergency and approve the method of work.
- 12.2 In the event of an environmental incident (e.g. a spillage), steps should be taken to prevent pollution, for example through:
- Protection of drains by the use of drain covers or booms;
  - Use of absorbent granules following an oil/chemical spill; and,
  - Turning off equipment or other sources of noise or dust.
- 12.3 Once the situation has been rectified, full details about the incident and remedial actions undertaken should be provided to the City of London and other relevant authorities, and recorded in the site complaints/incidents logbook.

## **13.0 Pollution Emergencies**

- 13.1 All sites should have a plan, equipment and training in place for dealing with pollution emergencies. A summary of the plan should be visibly displayed around site, and understood by all workers.
- 13.2 For more guidance on such planning, please see the Environment Agency guidance 'Pollution Prevention Pays – getting your site right', downloadable at:

## **14.0 Party wall work**

- 14.1 Work to party walls and major works in partially occupied buildings will be strictly controlled, and are usually barred between 09:00 and 17:00 hours when noise and/or vibration could be transmitted to neighbouring properties and businesses.
- 14.2 Vibration monitoring should be considered to reassure neighbours and assist in demonstrating that levels do not exceed those which may cause structural damage to adjoining buildings. Complaints relating to vibration can cause considerable delays, particularly during demolition piling and ground work phases of construction activities. Noise should also be considered to assist in determination of acceptable levels.
- 14.3 Where works are carried out close to, or on, a party wall, The Party Wall Act 1996 may apply. The Contractor must consider all aspects of this Act and allow sufficient time to comply with it.

## **15.0 Scaffolding and Gantries**

- 15.1 Scaffold erection or dismantling can cause disturbance to site neighbours. All works must be undertaken in accordance with the Environmental Services Guidance Notes for Activities on the Public Highway, and be subject to a licence under the 1980 Highways Act. Subsequent erection and dismantling activities must be agreed with the Pollution Team, and comply with prescribed times.
- 15.2 Appendix D sets out detailed information on the requirements of the City for scaffolding and gantries.

## **16.0 Cranes, Lifting of Heavy Equipment, and consequent Road Closures**

- 16.1 The erection of fixed cranes, rigging, and use of mobile cranes on the highway and lifting of heavy equipment often has to be undertaken outside normal working hours. All these street-based activities require prior consent from both the Environmental Services Highways Division and the Pollution Team. Although it is normally the crane company's responsibility to obtain prior approval for the works, the Contractor should ensure this has been done.

The Pollution Team's approval for the work is required to ensure that all plans are appropriate for the location, and that steps have been taken to mitigate any disturbance to commercial or residential neighbours. The application for this must be accompanied by a lifting plan.

- 16.2 The correct procedure involves firstly telephoning the Pollution Team to agree the outline proposals (0207 606 3030). Secondly, the 'mobile crane environmental health authorisation notice & structures notification form' (Appendix I), together

with a lifting plan, should be fully completed and faxed to the Pollution Team (020 7332 1316) for scrutiny/approval.

Once received, the completed application form will be checked, any necessary amendments agreed with the sender, and returned to the applicant with the appropriate signature. This can then be presented to the City's Street Management Office at a previously agreed appointment (020 7332 3553).

Note - The part of Appendix I relating to 'structures authorisation' must also be signed by the crane company's representative. It is the crane operators responsibility to check whether there are any underground 'structures' either under or in the vicinity of the highway where the crane operation is sited - see Appendix F for full details.

- 16.3 Crane oversailing must be agreed with the City of London and/or site neighbours. Under section 177 of the Highways Act 1980, site cranes require a licence if the jib at any point extends over the public highway. Application for this licence should be made to the Department of Markets and Consumer Protection Highways Division. A charge may be levied for oversailing the public highway.

## **17.0 Vehicle Movements and Deliveries**

- 17.1 All deliveries of materials and plant to the site and removal of waste should, where possible, be carried out within normal site working hours. Any early morning or evening deliveries must have approval from the Pollution Team. This should be requested using the copy of the Site Hours Variation Request Sheet (Appendix H).
- 17.2 The site layout should be designed to minimise potential effects on neighbours. A competent banksman should be employed to provide assistance to vehicles accessing and leaving the site, thereby ensuring minimal traffic disturbance and pedestrian safety.
- 17.3 Vehicle movements should be planned to ensure that Lorries do not arrive or depart outside standard hours. No daytime or night-time parking of lorries will be permitted outside agreed areas.
- 17.4 Where appropriate, deliveries should be arranged on a just-in-time basis in order to prevent vehicles queuing outside site.
- 17.5 The generation of dust whilst loading or unloading materials must be controlled by the use of chutes, bagging, sheeting and damping down. Where vehicles are leaving unpaved sites, adequate wheel washing arrangements should be employed to prevent contamination of the highway. Loads containing waste material leaving site should be sheeted before travelling on the highway.
- 17.6 Appendix F of this code summarises the City of London's traffic management requirements for vehicle movements, site deliveries, street closures, crane operations and abnormal loads. This can be copied for use of subcontractors and others.

## **18.0 Light Pollution**

- 18.1 Light pollution is now a statutory nuisance and is defined as any form of artificial light which shines outside the area it is required to illuminate. Unnecessary use of lights is considered a waste of energy. Any use of lighting should have regard to these facts and should be designed to prevent any nuisance to residents or road traffic and be used primarily for reasons of health and safety or security.
- 18.2 Site lighting will be located and aligned so as not to intrude into residential properties, on sensitive areas, or constitute a road or rail hazard.

## **19.0 Asbestos and other Hazardous Materials**

- 19.1 All work on asbestos and other hazardous materials must comply with current Legislation and HSE Approved Codes of Practice & Guidance.
- 19.2 Before any work is done or commissioned that is likely to disturb asbestos or other hazardous material, the following must be worked out:
- The amount of hazardous material;
  - Where it is and what condition it is in;
  - Whether work is likely to disturb material; and,
  - Whether and how the material needs to be safely protected or removed.

This can be achieved either by checking existing records (such as client's survey, asbestos plan or register) or commissioning a suitable survey before work starts. It is good practice to include the need for such a survey in the initial project cost and programme.

For more information, please see the following and associated links:

<http://www.hse.gov.uk/construction/healthrisks/asbestos.htm>

<http://www.hse.gov.uk/comah/index.htm>

## **20.0 Contaminated Sites**

- 20.1 The Contractor should obtain and review copies of any site investigations that have been carried out prior to their appointment and satisfy themselves that they have undertaken a thorough assessment of potential risks to:
- End users of the site;
  - Construction workers & others visiting the site;
  - Neighbours and members of the public;
  - The local environment (air, surface and ground water and land); and,
  - Construction materials (for example corrosion caused by sulphates).
- 20.2 If any contamination or ground gas is identified or suspected during the course of the works, the Contractor should undertake further specific investigations. Where

contamination is identified, the Pollution Team should be notified. All remedial work should be approved by the Pollution Team.

- 20.3 To enable classification of the waste for disposal purposes it is the Contractor's responsibility to arrange analysis of the waste material excavated.
- 20.4 An assessment should be undertaken of the potential for unexploded bombs to be present on the site. This should include consultation with the Home Office and the City Corporation. Any suspect devices encountered must be notified to the City of London Police and/or Metropolitan Police, all site work should be stopped and the site evacuated.

## **21.0 Waste Management**

- 21.1 Under the Site Waste Management Plan Regulations (2008), any project costing over £300k is required to produce a Site Waste Management Plan (SWMP). These will be enforced by both the City and the Environment Agency for new build, maintenance, and alteration or installation/removal of services (such as sewerage or water).

The purpose of a SWMP is to ensure that building materials are managed efficiently, waste is disposed of legally, and that material recycling, reuse and recovery is maximised. As such, a SWMP sets out how all building materials, and resulting wastes, are to be managed over the course of a project.

For more information, please consult the following websites:

<http://www.defra.gov.uk/environment/waste/topics/construction/index.htm>

<http://www.environment-agency.gov.uk/business/sectors/32729.aspx>

- 21.2 Those sites with a budget of less than £300k must manage their waste according to current legislation (see <http://www.environment-agency.gov.uk>). Evidence of how waste is disposed of, and efforts to reduce and recycle waste, must be maintained and kept on site
- 21.3 All site waste management must be planned and carried out in accordance with the Waste Management Hierarchy, as demonstrated below:

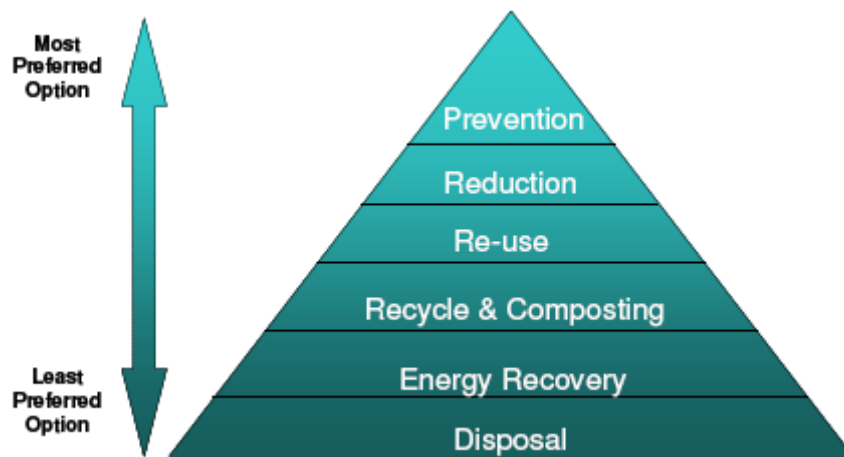

- 21.4 All wastes must be removed from sites using a registered waste carrier and sent only to disposal facilities authorised to receive it. Disposal must be in accordance with relevant legislation.
- 21.5 All waste documentation - transfer notes, consignment notes, exemptions, waste carrier and facility licences - must be held on site as required by legislation. Such documentation must be maintained to be readily available for inspection at all times.

## 22.0 Materials Handling and Storage

- 22.1 Materials should be stored in appropriate conditions to prevent damage/contamination, with storage areas and containers sited away from drains and un-surfaced areas. Storage containers should be fit for purpose, regularly inspected and maintained, and should all have secondary containment (such as a bund) to contain any leaks or spills.
- 22.2 Fuels should be stored in compliance with the Control of Pollution (Oil Storage) Regulations 2001.
- 22.3 Procedures and training should be in place for the safe delivery and handling of materials, with regular site inspections carried out to ensure that once on site they are stored safely and correctly.

## 23.0 Discharge of Waste Water from Sites

- 23.1 Wastewater generated from site activities including water from dewatering excavations, site run off slurry and bentonite are classified as trade effluent. These should not be discharged direct to surface or foul drains without the consent of the Environment Agency for controlled waters, and Thames Water for others.
- 23.2 The Contractor is responsible for obtaining necessary consents and ensuring compliance with any conditions imposed on them. Copies of consents must be held in a designated file kept on site.
- 23.3 In cases of heavy water run-off, sumps must be provided in order to deal with the issue.

## 24.0 Site Drainage, Temporary and Permanent Connections to Sewers

24.1 Contact must be made with the City of London Drainage Services Group (020 7332 1105) before any work is undertaken on connections to sewers or drains running under the public highway. The following general requirements will have to be met:

- All redundant sewer communication pipe work must be sealed off at the sewer. The remaining pipe work should be removed or filled with a suitable weak concrete, cement grout or other suitable material. This is to prevent any infestation by rodents and avoid the risk of future possible subsidence.
- All retained sewer communication pipes should be tested and a CCTV survey carried out to ensure they are suitable for the new development and in good condition.
- In order to prevent rodents or sewer gases reaching the site, temporary sewer communication pipes must be provided with a 'cascade' cast iron interceptor trap to British Standard specification.

It is strongly recommended that all under ground drainage systems are installed using pipes made of a robust material such as cast iron, and that inspection chambers etc. are properly sealed with bolted down covers. This will prevent later problems from damage by vibration or rodent access.

Wherever it is at all possible, the drainage system serving the proposed development or refurbishment should gravitate to the sewer. This will eliminate the need for pumping of foul drainage to the sewer and the associated problems which regularly occur with this type of installation.

The sewage system within the City of London is vented to atmosphere via vents at road surface level and any increase of discharge velocity resulting from pumped or stored sewage being discharged to the sewer frequently results in complaints of foul smells. These may well be treated as a statutory nuisance by this Department. The importance of designing a system which discharges to the sewer by gravity wherever practicable cannot be overstated.

**Note:** Details of the City's standard drainage connection requirements and the related legislation are shown in Appendix E.

## 25.0 Pest Control

25.1 The City of London has a statutory duty to take such steps as may be necessary to keep the City free from rats and mice this includes enforcement of the Prevention of Damage by Pests Act 1949.

When an occupier of any land, including a construction site becomes aware of an infestation by rats or mice in large number he must notify Port Health and Public Protection (0207 606 3030).

25.2 Appropriate measures must be taken to limit any insect, bird or rodent infestation. Such measures are considered essential to limit future problems in completed buildings - especially in the case of mice.

- 25.3 Pest control does not just include treatment by a pest control company; in fact this is a last resort. Measures should be taken to:
- Prevent access to the site principally from exposed drainage;
  - Reduce harbourage in order to ensure that rubbish or spoil is not left for long enough allow rodents to establish themselves above ground;
  - Limit potential food and water sources. It is particularly important to ensure that waste food or empty cartons are not left in areas where they can encourage rats and mice.

Many of the methods necessary to achieve adequate control should be part of established construction methods.

- 25.4 To report any problems with infestations, or if you require any additional advice, contact the following number: 0207 606 3030.

## **26.0 Conservation**

- 26.1 The Contractor must ascertain whether any trees on the site or in immediate area are either protected by Tree Preservation Orders or fall within a Planning Conservation Area prior to works starting. This may be done by contacting the Department of The Built Environment (Tree Officer) on 020 7332 1708.
- 26.2 Trees must be retained for the duration of the works. Works in the vicinity of trees should be undertaken in accordance with BS 5837:2005 'Trees in Relation to Construction. Recommendations'. In the event that it is impossible to retain trees whilst work is undertaken, they should be retained for as long as possible and only removed following consultation with the Directors of the City of London's Planning and Open Spaces Departments.
- 26.3 The City will require you to replace or treat damaged trees. Where replacement trees are required, the specification, number, location, and planting method must be agreed with the Open Spaces Department.
- 26.4 Prior to commencement of works on-site, an ecological survey should be undertaken by a qualified professional to confirm the absence of birds, bats and any other protected species which may be nesting/roosting within buildings or vegetation. If present, appropriate mitigation measures should be undertaken following consultation with the City's Department of Open Spaces who can be contacted on 0207 332 3505.

## **27.0 Archaeology and Built Heritage**

- 27.1 Much of the City of London is designated as being of archaeological potential. Archaeology is a material consideration of the planning process. Where archaeological remains survive, archaeological investigation and recording is required as a condition of the planning permission. This may be to ensure the preservation *in-situ* of important archaeological remains or to ensure that a record of the remains is made.

- 27.2 Some monuments and archaeological remains are scheduled ancient monuments under Part I of the Ancient Monuments and Archaeological Areas Act 1979 and scheduled monument consent is required to undertake any work that may affect a scheduled monument. Scheduled monument consent is obtained from the Department of Culture, Media and Sport and advice on this is available from English Heritage.
- 26.3 Some buildings and structures are included on the statutory list of buildings of special architectural or historic interest. Listed building consent is needed to carry out any work which may affect a building's special architectural or historic interest.
- 27.4 The Contractor should ensure that the Department of Planning and Transportation has been contacted to establish whether the site contains a listed building, scheduled ancient monument or archaeological remains, and what specific requirements are included in the planning permission, listed building consent or conservation area consent. This may include arrangements for a programme of archaeological work and recording to be carried out as an integrated part of the development, submitted to and approved by the Department of Planning and Transportation, before work commences. Contact on 020 7332 1447.

Details of any 'scheduled monument' consent should be obtained from English Heritage. Contact on 020 7973 3000.

## **28.0 Climate Change and Sustainability**

- 28.1 The City of London is working towards limiting the impact of the region and making it more sustainable, demonstrated by (among other projects) the current development of a Climate Change Strategy, and strongly encourages other parties to do the same. Innovation and best practice in this area will therefore be highly regarded in applications for the Environment Award through the CCS.
- 28.2 The Sustainable Development Commission has identified the following key priority areas for action in the UK:
- Sustainable consumption and production – greater efficiency in utilisation of resources and minimisation of waste;
  - natural resource protection; and,
  - climate change and energy – both reducing energy consumption and sourcing that energy from more sustainable sources.

Contractors should employ best practice and look for new innovative techniques in each of these priority areas, thus ensuring the process of construction or deconstruction is made more sustainable.

The impact of such techniques, or indeed highlighting of areas for improvement, can be demonstrated by including life cycle analyses for materials/processes or basic carbon footprinting in the EMP.

- 28.3 Examples of actions taken to increase the sustainability of the site could include:

- Use of the Mayor of London's Green Procurement Code, in particular via the procurement of FSC-approved/sustainable timber;
- Use of non-virgin aggregate;
- general good practice including ensuring that plant not in use is switched off and that lighting is used only when necessary (such as through the use of timers);
- Use of energy efficient bulbs or solar powered lighting;
- the use of existing feeds for power where possible to prevent the need for generators, or the purchasing of energy/electricity from sustainable sources;
- Employment of energy efficient and, where possible, gas powered plant as opposed to petrol/diesel;
- Efficient use of water as a resource, for example in cleaning systems or the implementation of rainwater harvesting.

28.4 For more information regarding climate change and sustainability issues relevant to a particular project or site, contractors are encouraged to contact the City of London Sustainability Team on 020 7332 1428, or read the Climate Change Adaptation Strategy available at

[http://www.cityoflondon.gov.uk/Corporation/LGNL\\_Services/Environment\\_and\\_planning/Sustainability/Climate\\_change/](http://www.cityoflondon.gov.uk/Corporation/LGNL_Services/Environment_and_planning/Sustainability/Climate_change/)



## **APPENDIX A: Guidance and Legislation**

### **General**

Environment Agency Pollution Prevention Guidance Notes  
Planning Policy Guidance Notes  
Town and Country Planning Act 1990  
Planning and Compensation Act 1991  
BS 6187: 2000 Code of Practice for Demolition  
ISO 14001

### **Vehicle Movements**

Highways Act 1980  
Road Traffic Regulations Act 1984

### **Noise and Vibration**

Environmental Protection Act 1990 (especially Sections 79 – 82)  
Control of Pollution Act 1974 (especially Section 60)  
BS 5228-1:2009 and BS 5228-2:2009, – Noise and Vibration Control on Construction and Open Sites  
BS 7385-2:1993 Evaluation and Measurement for Vibration in Buildings. Part 2 Guide to Damage Levels from Ground borne Vibration  
BS 6472:2008 Guide to Evaluation of Exposure to Vibration in Buildings (1Hz - 80Hz)  
Noise and Statutory Nuisance Act 1993  
Noise at Work Regulations 1989

### **Air Quality**

Environment Act 1995  
Air Quality (England) Regulations 2000  
Building Research Establishment draft Code of Practice on Controlling Particles from Construction and Demolition (2000)  
DEFRA (2001) UK Air Quality Strategy, HMSO, London  
Clean Air Act 1993  
The City of London Air Quality Strategy 2011-2015

### **Smoke and Fume Nuisance**

Noise and Statutory Nuisance Act 1993

### **Asbestos and Hazardous Substances**

The Control of Asbestos at 2006  
The Control of Asbestos in the Air Regulations 1990  
The Special Waste Regulations 1996 (as amended)  
Special Waste (Amendment) (England and Wales) Regulations 2001  
MDHS 100 "Surveying sampling and assessment of asbestos-containing materials" HSE Guidance Note 2002  
Control of Substances Hazardous to Health Regulations 2002 (as amended)  
Environmental Protection (Controls on Substances that Deplete the Ozone Layer) Regulations 1996  
Plus all other current or future Legislation together with HSE Approved Codes of Practice and Guidance

## **Waste Management**

Environmental Protection Act 1990  
Environment Act 1995  
Environmental Protection (Duty of Care) Regulations 1991  
Environmental Protection (Special Waste) Regulations 1996 (as amended)  
The Controlled Waste (Registration of Carriers and Seizure of Vehicles) Regulations 1991  
Waste Management Licensing Regulations 1994 (as amended)  
Waste Management Duty of Care Code of Practice (1996), HMSO

## **Contaminated Land**

Environment Act 1995  
Contaminated Land Regulations 2000  
Interdepartmental Committee on the Redevelopment of Contaminated Land (ICRCL 59/83)  
Contaminated Land Exposure Assessment documents, 2002  
Code of Practice for the Investigation of Potentially Contaminated Sites BS 10175:2001  
Landfill Tax Regulations 1996 (as amended)

## **Discharges and Site Drainage**

Environmental Protection Act 1990  
Environment Act 1995  
Water Resources Act 1991  
Water Industry Act 1991  
Trade Effluent (Prescribed Processes and Substances) Regulations 1989 (as amended)  
Anti-Pollution Works Regulations 1999

## **Pests**

Wildlife and Countryside Act 1981 (as amended)

## **Trees, Birds and Bats**

Town and Country Planning Act 1990  
Wildlife and Countryside Act 1981 (as amended)  
BS 5837:2005 Trees in Relation to Construction. Recommendations  
BS 3998:2010 Tree Work. Recommendations

## **Archaeology and Built Heritage**

Ancient Monuments and Archaeological Areas Act 1979  
Planning (Listed Buildings and Conservation Areas) Act 1990

## **City of London Documents**

Code of Practice for Deconstruction and Construction Sites  
Considerate Contractor Scheme (see Appendix C)  
Scaffolding and Hoarding Licences (see Appendix D)  
City's Standard Requirements for Sewer Connections (see Appendix E)  
Traffic Management Requirements (see Appendix F)

## **APPENDIX B: Contact details for City Departments and External Agencies**

**Postal address for all Internal Departments:** PO Box 270, Guildhall  
London, EC2P 2EJ  
**General Switchboard (24 hour service)** Tel: 020 7606 3030

### **MARKETS AND CONSUMER PROTECTION POLLUTION TEAM**

All enquiries: Tel: 020 7606 3030.  
Fax: 020 7332 1316  
Email: DES-EH-Pollution@cityoflondon.gov.uk

### **ENVIRONMENTAL SERVICES HIGHWAY MANAGEMENT GROUP**

Out of Hours in Emergency: Tel: 020 7606 3030 and ask for duty officer to be called. He or she will call you back.  
Considerate Contractor Scheme: Tel: 020 7332 1104  
Email: [carl.vaughan@cityoflondon.gov.uk](mailto:carl.vaughan@cityoflondon.gov.uk)  
Highways Section & Scaffolding Licences: Tel: 020 7332 1104/3578  
Fax: 020 7332 1578  
Parking dispensations & Highway Closures: Tel: 020 7332 3553  
Fax: 020 7332 3552  
City of London Drainage Group: Tel: 020 7332 1105  
District Surveyors: Tel: 020 7332 1000  
City Structures Officer Tel: 020 7332 1544

### **PLANNING AND TRANSPORTATION**

Tree Preservation Orders Tel: 020 7332 1708  
Listed Buildings – Consent to Work Tel: 020 7332 1447

### **OPEN SPACES DEPARTMENT**

Advice on birds, bats or plants found on site Tel: 020 7374 4127

### **THE CITY OF LONDON POLICE**

Postal Address: Wood Street Police Station  
37 Wood Street, London EC21 2NQ  
General Enquiries: Tel: 020 7601 2455  
Control Room (24 Hour operations): Tel: 020 7601 2222  
Abnormal loads & traffic planning: Tel: 020 7332 3122

### **THE MUSEUM OF LONDON ARCHEOLOGY SERVICE – ‘MOLAS’**

Postal Address: 46 Eagle Wharf, London, N1 7ED  
General Enquiries: Tel: 020 7410 2200  
Fax: 020 7410 2201

## **EXTERNAL AGENCIES**

### **THE ENVIRONMENT AGENCY**

Postal Address: Apollo Court  
2, Bishops Square Business Park  
St. Albans Road  
Hatfield,  
Herts, AL10 9EX

General Enquiries: Tel: 08708 506 506

### **HEALTH & SAFETY EXECUTIVE**

Postal Address: Rose Court  
2, Southwark Bridge Road  
London, SE1 4LW

24 Hour Emergency Contact:  
(construction, demolition  
& asbestos related matters)

Tel: General enquiries: 0845 3450055  
Tel: 020 7556 2102  
Fax: 020 7556 2109

### **THE METROPOLITAN POLICE**

Postal Address: New Scotland Yard  
Broadway  
London, SW1H 0BG

General Enquiries: Tel: 0300 123 1212  
Abnormal Loads Section Tel 020 8246 0931

### **LONDON FIRE & EMERGENCY PLANNING AUTHORITY**

Postal Address: 20 Albert Embankment  
London, SE1 7SD

General Enquiries: Tel: 020 7587 2000

*NB. The work previously carried out by the **Petroleum Inspectorate** is now shared between The Health & Safety Executive - in respect of most instances where fuel is dispensed or stored in large quantities and Building Control Officers in Local Authorities - in the case of ventilation & signage in underground car parks etc.*

### **ENGLISH HERITAGE**

Postal Address: 33, Saville Row, London, W1X 1AB

General enquiries: Tel: 020 7973 3000

### **TRANSPORT FOR LONDON**

Abnormal loads section Tel: 020 7474 4770

### **LONDON UNDERGROUND LTD**

Contact re underground structures etc. Tel: 020 7222 1234

### **PORT OF LONDON AUTHORITY**

General enquiries: Tel: 0147 456 2200

## **APPENDIX C: Considerate Contractor Scheme Information**

1. The Considerate Contractor Scheme (CCS) comprises:
  - a Code of Good Practice, covering care, cleanliness, consideration and cooperation;
  - regular inspections by the City's Considerate Contractor Surveillance Officers;
  - an annual judging and awards ceremony;
  - and a telephone hotline enabling the general public to comment on the Scheme, sites and on participating Contractors. (020 7332 1104) (email [Carl.Vaughan@cityoflondon.gov.uk](mailto:Carl.Vaughan@cityoflondon.gov.uk))

Note: general compliance with this Code of Practice is also a requirement of the scheme and sites will be judged and scored in this context.

2. The CCS is a co-operative initiative open to all Contractors undertaking building and civil engineering work in the City of London. There is no membership fee, but on joining the Scheme, members agree to abide by the Code of Good Practice. It is by following this voluntary Code that the general standards of works are raised and the condition and safety of City streets and pavements improved for the benefit of everyone living, working or just travelling through the Square Mile.

Membership of the CCS is actively encouraged for all construction and deconstruction works in the City.

Additional information and a copy of the code of practice can be obtained from The Environmental Services Highways Division representative on 020 7332 1104 or by email to [Carl.Vaughan@cityoflondon.gov.uk](mailto:Carl.Vaughan@cityoflondon.gov.uk)

3. An Environment Award is available as a separate achievement in the Considerate Contractor Scheme to recognise and encourage best practice and innovation in the sustainability of City construction and deconstruction. For details email [DES-EH-Pollution@cityoflondon.gov.uk](mailto:DES-EH-Pollution@cityoflondon.gov.uk)

## **APPENDIX D: Scaffolding & Hoarding Licence Requirements**

1. Under sections 168 and 169 of the Highways Act 1980, scaffolds and gantries on or over the Public Highway require a licence and must comply in all respects with the Environmental Services Highways Division's Guidance Notes for Activities on the Public Highway.
2. Under section 184 of the Highways Act 1980, temporary vehicle crossovers require a licence and should comply with section 13 of the Highways Division's Guidance Notes for Activities on the Public Highway.
3. Application for these licences should be made to the City by contacting Highways Division, Department of Markets and Consumer Protection. A site visit will usually be required. (020 7332 1104)
4. Scaffolding over the River Thames, on the foreshore or within 16 metres of flood defences requires consent under the byelaws of the Environment Agency, Thames Region and the Port of London Authority.
5. Requests for further information, copies of the guidance notes and licence applications should be made to the Highways Division (020 7332 3578).



**Department of Markets and Consumer Protection**  
**David Smith**  
**Director of Markets and Consumer Protection**  
**Jon Avern**  
**Port Health and Public Protection Director**  
City of London  
PO Box 270, Guildhall  
London EC2P 2EJ  
Facsimile 020 7332 1316  
[www.cityoflondon.gov.uk](http://www.cityoflondon.gov.uk)

### **The City of London Sewers Act 1848**

#### **City of London Standard Requirements**

1. All communicating drains to the sewer outfall **must** be provided with a cast iron intercepting/disconnecting trap which has a cascade, with access to the crown of the trap and have rodding access through to the sewer as BSS figure 26 or equivalent (for rodent control measures).
2. The communication pipework should be laid in straight lines in the vertical and the horizontal alignments and with no other pipe connections. (e.g. at a self-cleansing velocity and in a straight line from interceptor to the sewer).
3. The interceptor should be located inside the property boundary and adjacent to the buildings curtilage.
4. There should be provision to provide ventilation to the low invert level of a drainage system; this should normally be at the intercepting trap. It may be difficult to evaluate air movement precisely and therefore as guidance you should allow for the vent pipe to be half diameter at the size of the intercepting trap. This vent should be discharged to a safe outlet at roof level atmosphere.

#### **NOTES**

- a) The sewage system within the City historically vents to atmosphere via low level vents and any increases in discharge velocity (e.g. pumped drainage) of building effluent to the sewers results in the incidences of smells being reported. As justified smell complaints are treated as a statutory nuisance by this Department, it is **STRONGLY RECOMMENDED** where practicable and safe to do so all drainage should discharge via gravity.
- b) In the view of this authority there are rodents present within the sewers and special rodent control is therefore required; historically the measures this authority accepts are both by means of an interceptor trap and a sealed drainage system. You should discuss this matter with your Building Control Advisor/Inspectorate.
- c) There is a requirement under Section 62 of the Building Act 1984 for any person who carries out works which result in any part of a drain becoming permanently disused that they shall seal the drain at such points as the local authority may direct. You should therefore make arrangements to seal off any redundant communication drains connecting to the Thames Water Utilities (TWU) sewer at the point of communication with the local sewer and at the buildings curtilage.

Any failure in respect of these requirements may result in: -

1. *Charging of costs and expenses involved in attending site and auditing works.*
2. *Copies of documents concerning any default being placed on our Land Charges Register and disclosed to all subsequent enquiries*
3. *Charging for remedial works done in default and costs recovered from responsible person(s) which may be substantial in terms of cost and delays to the project.*

- **You are advised to submit proposals in writing concerning these matters to the above address:-**

## **Drainage Guidance and Legislation**

Environmental Protection Act 1990

Environment Act 1995

Water Resources Act 1991

Water Industry Act 1991

Trade Effluent (Prescribed Processes and Substances) Regulations 1989 (as amended)

Anti-Pollution Works Regulations 1999

The City of London Sewers Act 1848.

The Building Act 1984.

If you require any further advice or information on this matter, then please do not hesitate to contact Mr Richard Lambert on 0207 332 3026 or email [richard.lambert@cityoflondon.gov.uk](mailto:richard.lambert@cityoflondon.gov.uk). He is normally available, Monday to Friday, 09.00-10.00 a.m. and 15.00 – 15.45 p.m. at the above address.

SECTION A-A (CONNECTIONS UPTO 225mm)

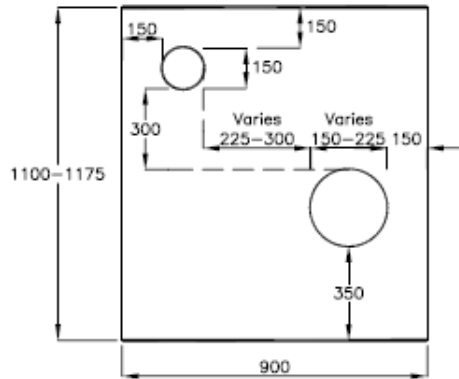

SECTION A-A (CONNECTIONS OVER 225mm)

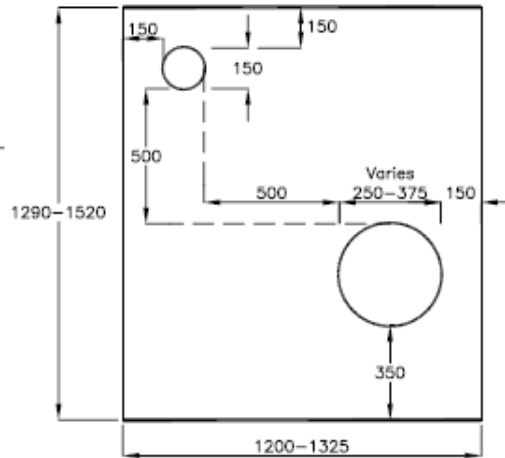

S.C.V.G. – Self Cleansing Velocity Gradient

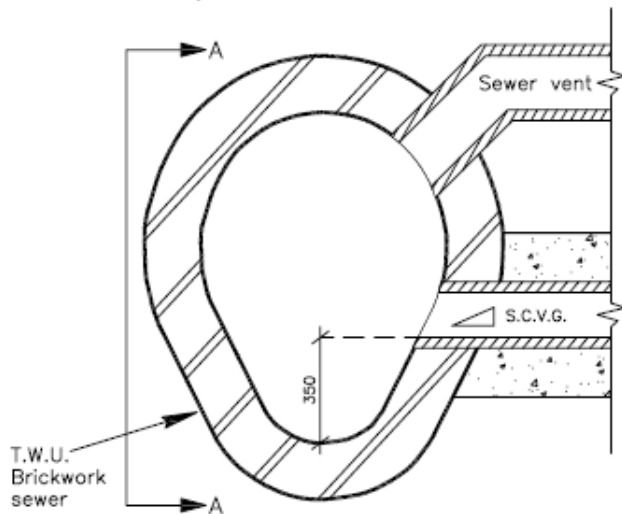

Safe outlet at roof level to atmosphere

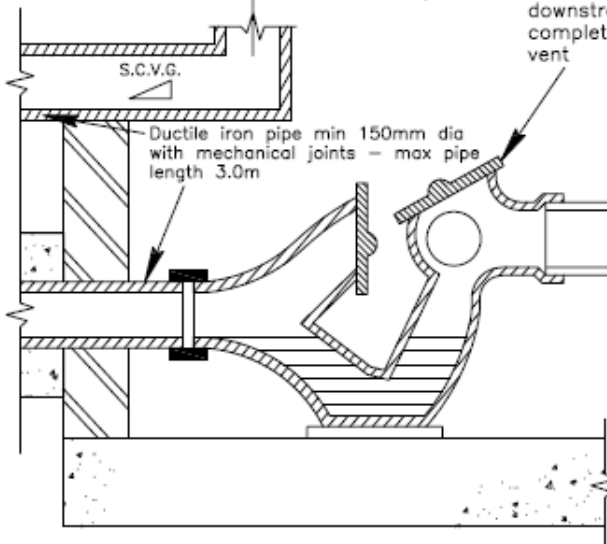

**NOTES:**

- 1) THE SEWER VENT WILL ONLY BE REQUIRED ON THOSE DEVELOPMENTS WHERE IT IS A MANDATORY PLANNING REQUIREMENT.
- 2) ALL HEADING CONSTRUCTIONS TO ACCOMMODATE A VENT WILL REQUIRE APPROVAL IN PRINCIPAL VERIFIED BY THE CITY SURVEYOR.
- 3) VENT PIPE MATERIAL SPECIFICATION:  
 WITHIN HEADING—SAME SPECIFICATION AS SEWER CONNECTION.  
 WITHIN BUILDING—THE MATERIAL SHOULD HAVE A TECHNICAL STANDARD FOR THE PURPOSE PROPOSED. REFER TO APPROVED DOCUMENT H1 FOUL WATER DRAINAGE.
- 4) NO ACCESS SHALL BE PROVIDED TO THE PIPE IN ITS ENTIRETY. THE PIPE WORK SHALL BE CLEARLY LABELLED AS 'SEWER VENT PIPE' NO CONNECTION TO BE MADE' AS AND WHERE ACCESSIBLE.
- 5) THE LOCATION AND INSTALLATION SHALL BE TO THE SATISFACTION OF THE DIRECTOR OF PLANNING AND THE DIRECTOR OF ENVIRONMENTAL SERVICES.
- 6) THE INSTALLATION AND TESTING SHALL BE IN ACCORDANCE WITH ALL CURRENT LEGISLATION AND SHALL BE TO THE SATISFACTION OF THE DIRECTOR OF ENVIRONMENTAL SERVICES.
- 7) RODENT CONTROL DEVICES WILL BE REQUIRED TO BE INSTALLED AT ROOF LEVEL.
- 8) CONNECTIONS TO BE CONSTRUCTED AND MADE GOOD CONSECUTIVELY.

Notes  
Do not scale. All dimensions to be checked on site.  
Errors to be reported to supervising officer.

B	SECTION DETAILS UPDATED AND EXTRA NOTES ADDED	S.B.	JUNE08
A	SEWER VENT ADDED	S.B.	MAY08
Rev		Drawn	Date

  
 Drawing produced by CITY SURVEYOR'S DEPARTMENT  
 On behalf of:  
 ENVIRONMENTAL SERVICES  
 P A Dent, BSc, CEng, MSc, IME  
 (Director of Environmental Services)  
 PO BOX 270, GUILDHALL, LONDON, EC2P 2EJ  
 Tel : 020 7606 3030 Fax : 020 7332 1963

Project : <b>HIGHWAY DRAINAGE</b>		Drawing : <b>TYPICAL SEWER AND VENT CONNECTION</b>	
Scale at A4 : <b>N.T.S.</b>	Drawn by : <b>S.B.</b>	Drawing No: <b>AL15/11v</b>	
Des : <b>P.J.</b>	App :		
Date : <b>MAY 08</b>	Pro code UPRN	Revision	<b>A B</b>

## **APPENDIX F: Traffic Management Requirements**

### **General**

The Contractor will be required to use designated traffic routes. These must be agreed during the site operations planning stage with the Department of Markets and Consumer Protection Highways Management Group (020 7332 3993).

If necessary, proposed routes will also be discussed with The City Police (020 7601 2143), Transport for London (020 7474 4770), Port Health and Public Protection (020 7606 3030) & The Metropolitan Police. (020 7230 1212).

Whenever possible vehicles must enter and exit the site in a forward direction, any exceptions to this rule must have prior consent from the Department of Markets and Consumer Protection Highways Division (020 7332 3578).

A competent banksman should be provided to assist your drivers accessing & leaving sites where there are busy streets etc., thereby ensuring pedestrian safety & minimal disturbance to other traffic.

Deliveries to the site should be properly co-ordinated. Parking in local streets whilst waiting for access to the site is not permitted. A 'parking dispensation' will be required for vehicles unloading or loading in the street. (Contact the Traffic Management Office on 020 7332 3553 to arrange this)

The contractor will be held responsible for any damage caused to the highway by site activities and will be required to carry out the temporary or permanent reinstatement of roads, kerbs, footpaths & street furniture to the satisfaction of the City.

The City encourages use of systems where vehicles serving sites regularly are identified by prominently displayed notices.

Contractors must not allow mud or other spoil from sites onto the highway adjacent to the site. Wheel washing plant or other means of cleaning wheels must be used before vehicles leave unpaved sites.

### **Arranging road closures in connection with crane & other heavy lifting equipment deliveries.**

The correct procedure involves firstly telephoning the Pollution Team to agree the hours of operation and noise implications of your outline proposals on 020 7606 3030.

**The 'mobile crane environmental health authorisation & structures form'** – 'Appendix I' should then be completed and faxed to the Pollution Team on 020 7332 1316 for approval.

Once received, the completed form will be checked, any necessary amendments agreed with the applicant and returned to the applicant signed by the authorising officer.

Formal application for any crane operation and / or road closure must then be made in person to the Department of Markets and Consumer Protection' Traffic Management Office. Applications

will only be considered by appointment, and applicants must have details of the proposed date, time and nature of the operation at this time. Also, a completed 'Appendix I' signed by the authorising officer must be presented, together with the appropriate payment. For details of current charges or to make an appointment, telephone 020 7332 3553.

### **Important Note- Underground 'Structures'**

The part of Appendix I relating to 'structures authorisation' must also be signed by the crane company's representative before it is presented to The Traffic Management office. It is the crane operators responsibility to check whether there are any underground 'structures' such as subways, car parks, vaults or railway tunnels under, or adjacent to the part of the highway where the crane is to be sited.

Operators must contact the City's Structures officer on 020 7332 1544 to discuss the operation and, if required, the owners of any private underground structures such as London Underground Ltd. (020 7222 1234)

### **Abnormal Loads**

Prior permission for any **abnormal loads** (as specified in legislation enforced by the City of London & Metropolitan Police forces) is required from The City of London Police's traffic planning section (020 7601 2143) & The Metropolitan Police's abnormal loads section (020 8246 0931). Generally, such deliveries have to take place on weekdays after 19.00 hours or at weekends and may also require prior agreement from 'Transport for London'. Contact 020 7474 4770



**Department of Markets and Consumer Protection**

**Port Health and Public Protection – Pollution Team**  
City of London, PO Box 270, Guildhall, London EC2P 2EJ  
Tel No: 020 7606 3030  
Fax No: 020 7332 1316  
Out of Hours Contact No: 020 7606 3030

**APPENDIX G: SITE INFORMATION SHEET**

*This form must be completed and forwarded to the Environmental Health and Public Protection, Pollution team within 5 days following the start of activities on site.*

<b>Date:</b>	
<b>Contractor:</b>	
<b>Contractor Contact:</b>	
<b>Client Name, Address and Contact Number:</b>	
<b>Site Name and Address:</b>	
<b>Direct Number:</b>	
<b>Fax Number:</b>	
<b>24 Hour Contact Number:</b>	
<b>Additional/Useful Contact Names and Numbers:</b>	
<b>Proposed Working Hours:</b>	
<b>Company Contact(s) for Operation(s):</b>	
<b>Brief Details of Works to be Carried Out:</b>	

<b>Approximate Duration of Works:</b>	
<b>Plant and/or tools to be used and likely to be noisy:</b>	
<b>Works predicted to be noisy / or cause vibration and their location:</b>	
<b>Mitigation measures to minimise noise and vibration levels:</b>	
<b>Works generating dust and control measures</b>	
<b>Residents and businesses likely to be affected:</b>	
<b>Method of notifying residents and businesses</b>	
<b>Site Plan to be attached</b>	

**For Environmental Health and Public Protection Use:**

<b>Officer/s</b>	<b>Contact numbers</b>

<b>Name:</b>	
<b>Signature:</b>	
<b>Position:</b>	
<b>Date:</b>	



**Department of Markets and Consumer Protection**

**Port Health and Public Protection – Pollution Team**  
**City of London, PO Box 270, Guildhall, London EC2P 2EJ**  
**Tel No: 020 7606 3030**  
**Fax No: 020 7332 1316**  
**Out of Hours Contact No: 020 7606 3030**

**APPENDIX H: SITE HOURS VARIATION REQUEST SHEET**

*This form must be completed and faxed to the Pollution Team on the above number at least 5 days before the activities are to take place. The site hours requested can only be worked if approval is given and this form is countersigned by relevant Environmental Health Officer(s).*

<b>Date:</b>				
<b>Company:</b>				
<b>Company Contact:</b>				
<b>Company Contact for Operation:</b>				
<b>Site Name and Address:</b>				
<b>Direct Number:</b>				
<b>Fax Number:</b>				
<b>Operation(s) including location on site:</b>				
<b>Date of operation(s)</b>				
<b>Proposed Working hours:</b>				
<b>Company contact(s) for operation(s):</b>				
<b>Details of operation(s):</b>				
<b>Reasons for the operation(s):</b>				
<b>Plant and/or tools used:</b>				
<b>Predicted noise levels at sensitive location<sup>1</sup></b>	<b>Location</b>	<b>High</b>	<b>Medium</b>	<b>Low</b>

<b>Mitigation measures to minimise high and medium levels of noise:</b>	
---	--

<sup>1</sup> <b>Criteria for predicted noise levels</b>	
<b>High</b>	Operations that involve frequent mechanical impact, large numbers of plant and/or are continuous for 30 to 60 min. in every 1 hour.
<b>Medium</b>	Operations that involve manual impact noise, movement of plant (e.g. excavation, movement of materials etc) and/or are continuous for 10 to 25 min. in every 1 hour.
<b>Low</b>	Little or no perceptible noise above background levels at receptor, manual activities, limited plant and/or are continuous for up to 10 min. in every 1 hour.

<b>Residents and businesses likely to be affected. e.g. addresses, site maps etc.</b>	
<b>Notification method Proposed. (copies of written communications to be included)</b>	

**For Environmental Health use:**

**Variation Number:** \_\_\_\_\_

**Variation Granted: YES/NO** (delete as appropriate)

If YES, any additional comment/specific conditions:

--

If NO, please provide brief details/reasons:

--

<b>Name:</b>	
<b>Signature:</b>	<i>Environmental Health Officer</i>
<b>Date:</b>	



**APPENDIX I: MOBILE PLANT ENVIRONMENTAL HEALTH AUTHORISATION NOTICE & STRUCTURES NOTIFICATION**

*This form must be presented to the Street Management Office at your appointment, signed by the relevant Environmental Health officer(s).*

<b>Company Name:</b>	
<b>Contact Name:</b>	
<b>Fax No:</b>	
<b>Telephone No and Site Contact Mobile No:-</b>	
<b>Company Address</b>	
<b>Street Name &amp; Location (Where operation is to take place):</b>	
<b>Type Of Operation:</b>	
<b>Are any noisy operations involved?</b>	
<b>Weight of Crane:</b>	
<b>Type Of Traffic Prohibition:</b>	
<b>Date Of Street Management Services Appointment:</b>	

(Times Requested): (please state **TIMES** below in the relevant section)

<b>(Monday-Friday)</b>	
<b>(Saturday Only)</b>	
<b>(Sunday Only)</b>	
<b>(*Friday/Saturday-Sunday)</b> <i>(please also state non operational times) (*delete where necessary)</i>	

**Authorisation Declaration (to be signed by environmental officer)**

<b>State Name:</b> (of environmental officer) [see Map]	<b>Authorised Signature:</b>	<b>Date:</b> (of confirmation)

**B STRUCTURES AUTHORISATION NOTICE**

Are there any underground City of London or Privately owned structures? (See List for Corp of London structures).		If YES, please provide documentation that permission has been provided.	Signature of Crane Representative:
Yes	No		Date:

If you fail to produce this form (signed by environmental health and crane company) at your appointment, you may have to book another appointment which will delay your operation.

**To be completed by Street Management Services Officer at appointment:**

<b>INDEMNITY NUMBER:</b>		<b>DATES AGREED:</b>	
<b>SMS OFFICER:</b>			
<b>DATE:</b>			

APPENDIX J

Residential Streets Map

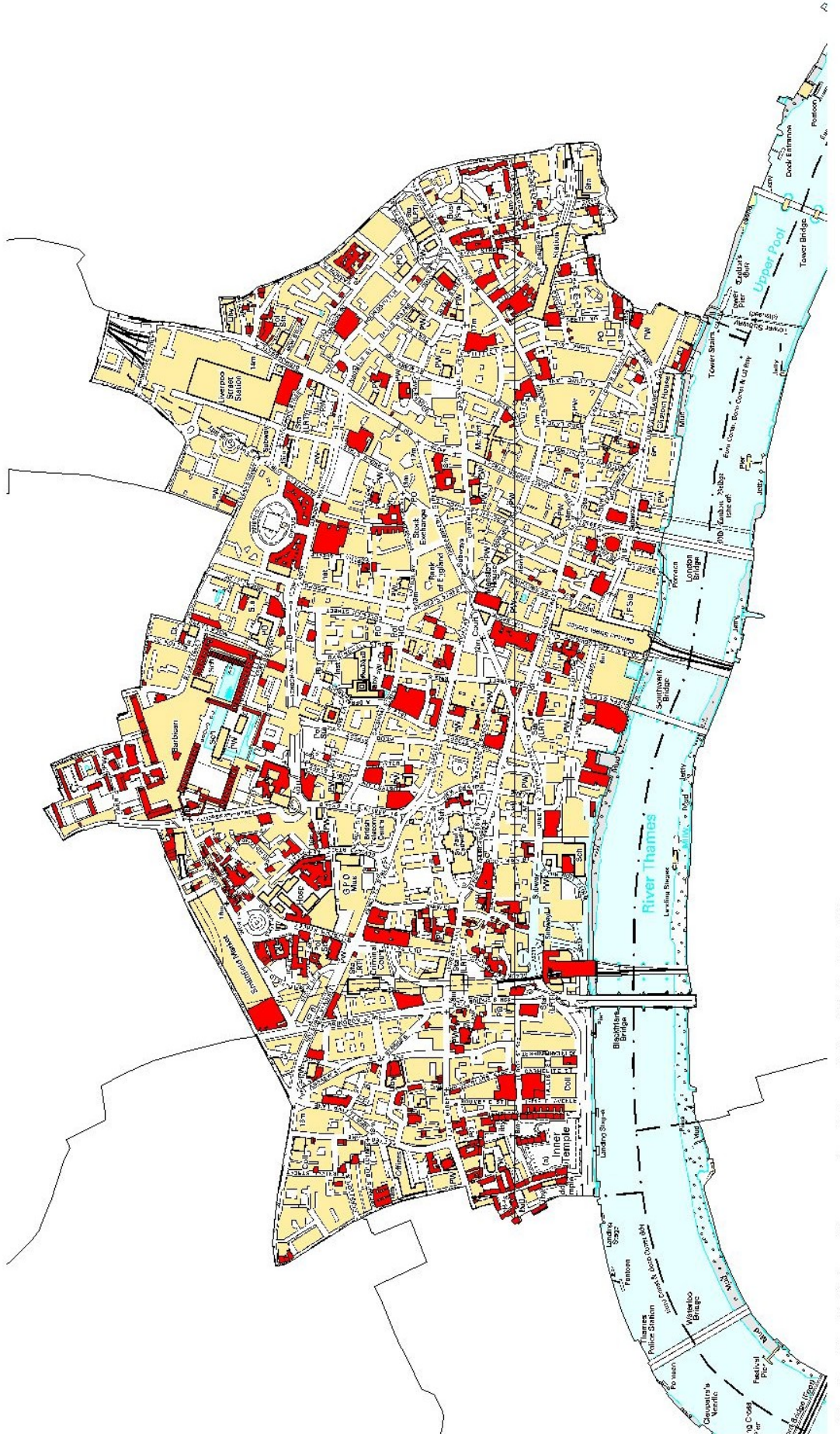

Reproduced from the Ordnance Survey mapping with the permission of the Controller of Her Majesty's Stationery Office © Crown copyright. Unauthorised reproduction infringes Crown copyright and may lead to prosecution or civil proceedings.  
 Corporation of London, Licence No. LA 087254, 2002



**Department of Markets and Consumer Protection  
Code of Practice for Deconstruction & Construction Sites Check List**

Site Address: \_\_\_\_\_

Contractor: \_\_\_\_\_

Contact Telephone Number: \_\_\_\_\_ Emergency Telephone Number (24hr): \_\_\_\_\_

<b>A.</b>	<b><u>Documentation to be held on site (CoP 4.0)</u></b>	
	Site information sheet completed	Y/N
	Environmental Management Plan (EMP)	Y/N
	Complaint and dust incident log with actions taken	Y/N
	Vibration and dust monitoring results	Y/N
	Environmental noise, dust, vibration and any other monitoring undertaken (see 14.0 below)	Y/N
	Liaison meeting minutes, newsletters, letters to neighbours etc	Y/N
	Site hours variation sheets	Y/N
	Inventory of all Non road mobile machinery with details of after treatment technology	Y/N
	Inventory and timetable of dust generating activities	Y/N
<b>B.</b>	<b><u>Liaison Protocol (CoP 5.0)</u></b>	
	Pre start up site meeting with the Pollution Team	Y/N
	Sensitive neighbours identified and listed e.g. residential, lunchtime premises and other sensitive receptors	Y/N
	Liaison officer appointed to deal with/inform neighbours	Y/N
	All neighbours informed of work timetable/extent and site contact information	Y/N
	Evidence of communication with neighbours (at least fortnightly)	Y/N
	Display board with site contacts	Y/N
	Site hours variation sheets being used for prior approval of works outside normal working hours.	Y/N
<b>C.</b>	<b><u>Hours of Work (CoP 6.0)</u></b>	
	Standard hours worked	Y/N
	Quiet hours observed (specified or checklist for monitoring)	Y/N
	Structural borne noise including party wall work identified and hours of work agreed with Pollution Team/Neighbours	Y/N
<b>D.</b>	<b><u>Vehicle Movement &amp; Deliveries (CoP 8.0)</u></b>	
	Traffic management plan	Y/N
	Vehicle movements to the site minimised	
	Site hours observed in respect of deliveries	Y/N
<b>E.</b>	<b><u>Light Pollution (CoP 13.0)</u></b>	
	Site lighting positioned to prevent nuisance to residents or road traffic	Y/N
<b>F.</b>	<b><u>Noise &amp; Vibration (CoP 14.0)</u></b>	
	Best Practical Means employed.	Y/N
	BMP considerations detailed in Environmental Management Plan should address the following :-	
A	Use of breakers kept to a minimum (leading edges etc)	Y/N
B	Main demolition carried out with hydraulic crushing plant e.g. munchers, crushers, nibblers etc.	Y/N

	C	Diamond sawing / cutting use / option considered	Y/N
	D	Other quiet methods considered / used	Y/N
	E	Removing of spoil from upper floors by skip	Y/N
	F	Isolation of deconstruction works from sensitive neighbours	Y/N
	G	Bored or hydraulically jacked piling rigs. Fully “silenced” engines up to Euro standards and no reversing Kelly / auger bars	Y/N
	H	Mains electric powered equipment used, “super silent” generator supply when mains not available.	Y/N
	I	Off site preparation where possible e.g. cutting of decking	Y/N
	J	Static plant positioned away from neighbours and provided with acoustic housing	Y/N
	k	Impervious hoardings 5kg/M <sup>2</sup> > surface density erected	Y/N
	L	Existing non-sensitive structures and site materials positioned as noise shields	Y/N
	M	Existing facades and boundary walls left as long as possible. Windows boarded / bricked up.	Y/N
<b>G.</b>		<b><u>Monitoring (CoP 14.7 – 14.12) (See section A)</u></b>	
		Noise and vibration monitoring carried out and results available.	Y/N
		Ongoing dust monitoring of large sites	Y/N
<b>H.</b>		<b><u>Air Quality and Dust (CoP 15.0) (See Section A)</u></b>	
		List of all dust and emission control methods to be employed	Y/N
		Wrap buildings to be demolished	Y/N
		Provision for wheel washing on site	Y/N
		Details of fuel stored on site	Y/N
		Use of Ultra Low Sulphur Diesel (if available)	Y/N
		Non road mobile machinery fitted with particle traps (if available)	Y/N
		All loads covered when leaving site	Y/N
		Authorised on site personnel with knowledge of pollution controls and vehicle emissions	Y/N
		Sit personnel trained in best practice for dust control	Y/N
		Innovations are specifically taken on site to improve environmental conditions (see CoP 4.0):	Y/N
		a) How are they reported (who to, why and where etc)	
		b) How are they monitored (by whom, when and where etc)	
<b>I.</b>		<b><u>Waste Management (CoP 19.0)</u></b>	
		Waste Management Plan (provided separately or part of EMP) (see CoP 4.0).	Y/N
		Generation of waste kept to a minimum by re-use, recycling, back filling with site spoil minimum packaging for site plant / materials	Y/N
<b>J.</b>		<b><u>Site Waste Water (CoP 20.0)</u></b>	
		Consent waste water generated as trade effluent obtained	Y/N
		Dewatering of site via settlement tanks and reuse for watering down dust etc.	Y/N
		List of chemicals to be added to water to improve dust suppression (see EMP CoP 4.0)	Y/N



## Considerate Contractor Scheme Environment Award 2011 Application Form

### 1. General Information

1.1 Company name and registered office address

.....  
.....  
.....  
.....

1.2 Address of relevant City site (if applicable)

.....  
.....  
.....  
.....

1.3 Name, telephone number(s) and email address of the main contact

Name:.....

Tel:.....

Email.....

**2. Environmental Innovation**

2.1 Details of the technique, equipment or management system that demonstrates environmental innovation. Please use additional sheets or other supporting information as necessary.

.....  
.....  
.....  
.....  
.....  
.....  
.....  
.....  
.....  
.....  
.....  
.....  
.....  
.....  
.....  
.....  
.....  
.....  
.....  
.....  
.....

2.2 Please state briefly what positive effect this will have on the environment

.....  
.....  
.....  
.....  
.....  
.....  
.....  
.....  
.....  
.....

Deadline for applications will be published online at the following address:  
[http://www.cityoflondon.gov.uk/Corporation/LGNL\\_Services/Environment\\_and\\_planning/Pollution/pollution+control.htm](http://www.cityoflondon.gov.uk/Corporation/LGNL_Services/Environment_and_planning/Pollution/pollution+control.htm)

Application forms should be submitted to the following address.

Andrew Dawson  
Department of Markets and Consumer Protection  
PO Box 270  
Guildhall  
London EC2P 2EJ  
Email [andrew.dawson@cityoflondon.gov.uk](mailto:andrew.dawson@cityoflondon.gov.uk)  
Tel: 0207 332 3619